

Study Session

3

2018 SBC 701 Sections 308 through 316 General Regulations II

OBJECTIVE: To develop an understanding of those general provisions regarding plumbing systems that are not specifically addressed in other chapters of the code. To develop an understanding of the provisions that apply to materials in all plumbing applications

REFERENCE: Sections 308 through 316, 2018 *Saudi Plumbing Code*

- KEY POINTS:**
- What piping is required to be supported? What seismic requirements apply?
 - What types of materials are permitted to be used for hangers, anchors and supports?
 - How is the interval of support for both horizontal and vertical piping determined?
 - When is sway bracing required?
 - When are piping restraints required, and what methods are acceptable?
 - What requirements apply to hot and cold water piping installed in bundles?
 - What regulations apply to plumbing systems and equipment installed in flood hazard areas?
 - What plumbing systems are required to be located above the designated flood elevation?
 - What plumbing systems are permitted to be located below the designated flood elevation?
 - What light, ventilation and interior finish requirements apply to washrooms and toilet rooms?
 - What plumbing facilities are required for construction workers?
 - When is testing required for piping systems? What are the methods for testing?
 - What criteria apply to the maximum increments in test gauges?
 - When is pressure air testing not permitted?
 - What test requirements apply to shower liners?
 - What components of a plumbing system require annual inspection and testing?

- KEY POINTS:**
- (Cont'd)**
- What requirements apply to the collection and disposal of condensate wastes?
 - When are auxiliary systems required for the disposal of condensate wastes?
 - When are traps required for condensate piping systems?
 - When are pipe penetrations required to be sealed? What materials are approved for sealing around the pipes?
 - How are pipe penetrations of fire-resistance-rated assemblies regulated?
 - What specific design, submittal, documentation and inspection requirements apply to alternative engineered designs?

Topic: Sway Bracing

Category: General Regulations

Reference: SBC 701-308.6

Subject: Piping Support

Code Text: *Rigid support sway bracing shall be provided at changes in direction greater than 45 degrees (0.79 rad) for pipe sizes 100 mm and larger.*

Discussion and Commentary: For larger pipes, hangers alone may not be sufficient to resist the forces created by water movement within the piping. Therefore, rigid bracing is required to restrict or eliminate lateral movement of both horizontal and vertical piping.

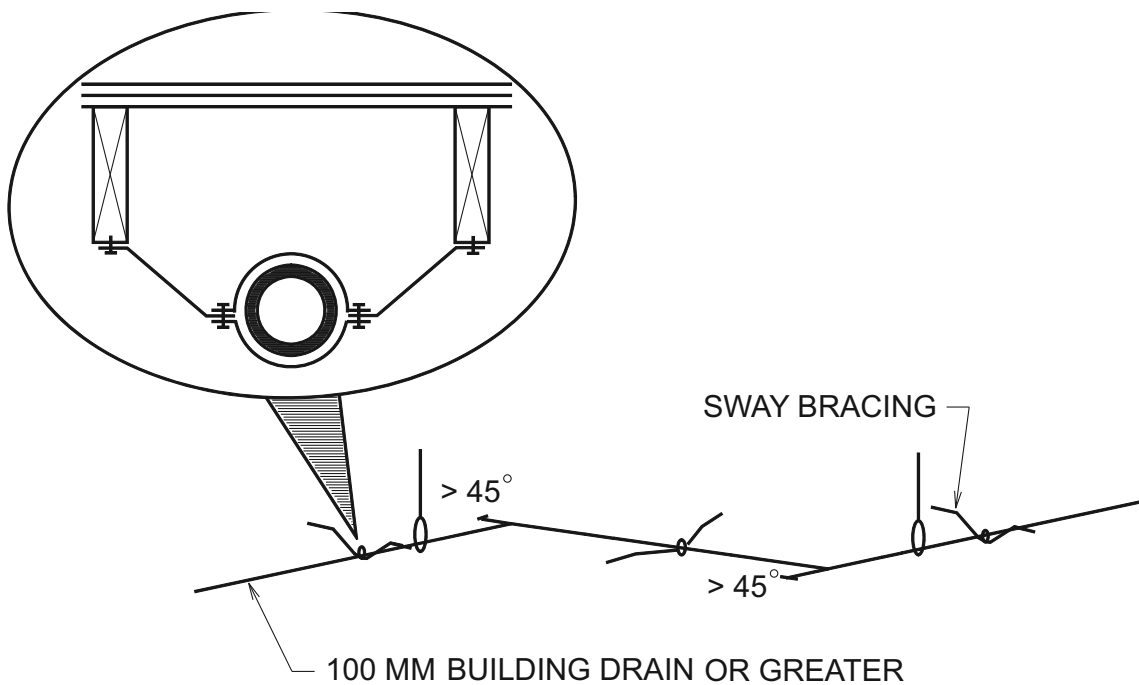

The maximum vertical and horizontal spacing between supports depends on the size and type of pipe. Supports must occur at frequent intervals for horizontal piping because of the potential for sagging. Although vertical piping typically requires support only at each story height, nonmetallic piping requires a mid-story guide or closer spacing.

Code Text: *Anchorage shall be provided to restrain drainage piping from axial movement. For pipe sizes greater than 100 mm, restraints shall be provided for drain pipes at all changes in direction and at all changes in diameter greater than two pipe sizes. Braces, blocks, rodding and other suitable methods as specified by the coupling manufacturer shall be utilized.*

Discussion and Commentary: This section requires a method of resisting axial movement of piping systems in order to prevent joint separation, regardless of the type of fittings or connections used. In particular, mechanical couplings using an elastomeric seal (typically hubless piping systems) have a limited ability to resist axial movement (pulling apart); therefore, pipe restraints must be provided to prevent joint separation. Section 308.7.1 requires axial restraints for pipe sizes 100 mm and greater at each change in direction and at each location with a change greater than two pipe sizes. Such joints also have a limited ability to resist shear forces. The hanger and support system must, therefore, prevent the couplings and connections from being subjected to shear forces that can damage the joint.

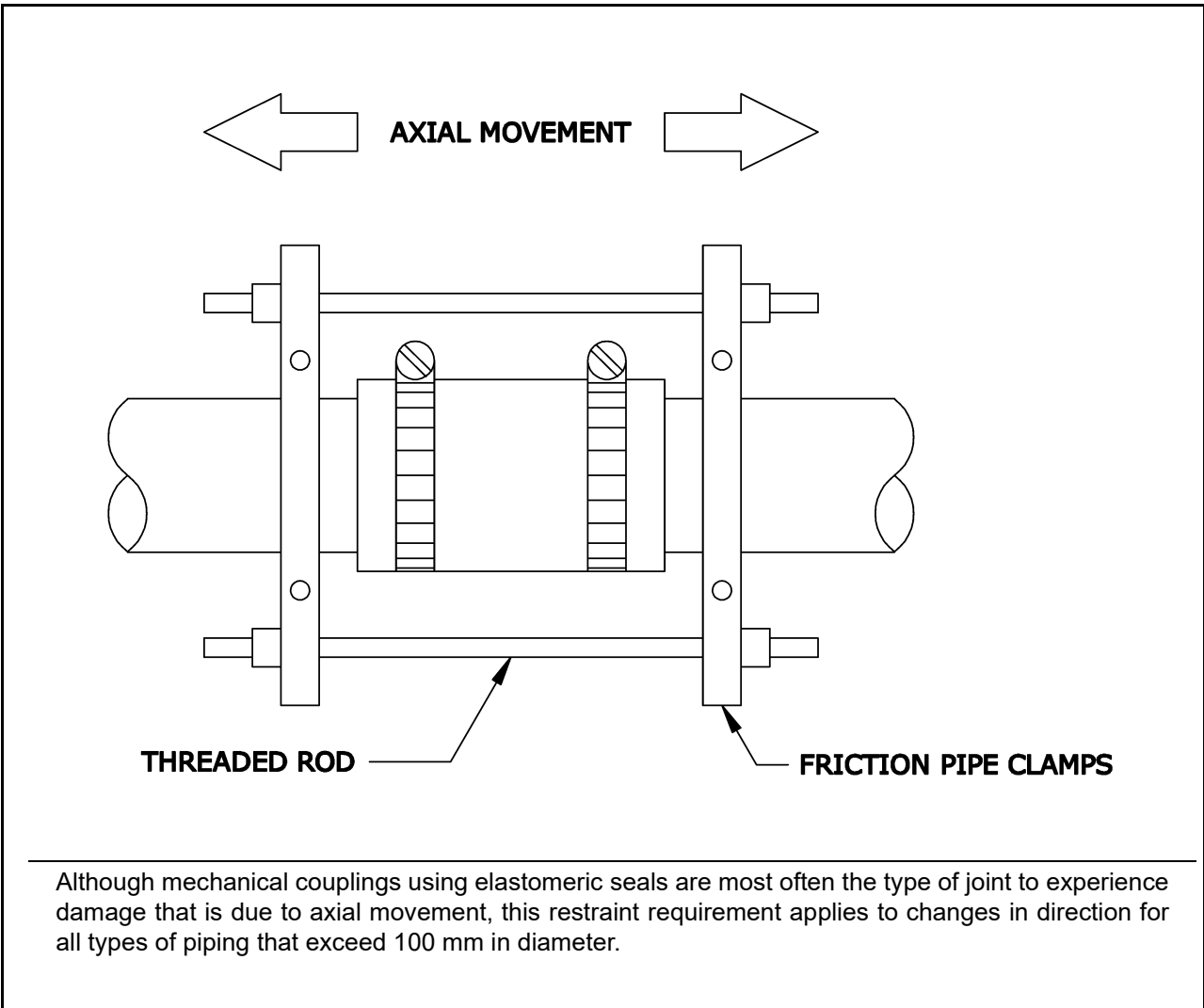

Although mechanical couplings using elastomeric seals are most often the type of joint to experience damage that is due to axial movement, this restraint requirement applies to changes in direction for all types of piping that exceed 100 mm in diameter.

Code Text: *Piping bundles for manifold systems shall be supported in accordance with Table 308.5. Support at changes in direction shall be in accordance with the manufacturer's instructions. Where hot water piping is bundled with cold or hot water piping, each hot water pipe shall be insulated.*

Discussion and Commentary: Typically, manifold systems distribute individual water supply lines to each fixture using PEX or some other semirigid plastic piping or tubing. The individual lines may be bundled together, and such bundles are treated as a single unit for determining hanger spacing. Installation also must comply with the manufacturer's installation instructions, which include the required supports at changes in direction to maintain a smooth transition without damaging, deforming or reducing the cross-sectional area of the piping.

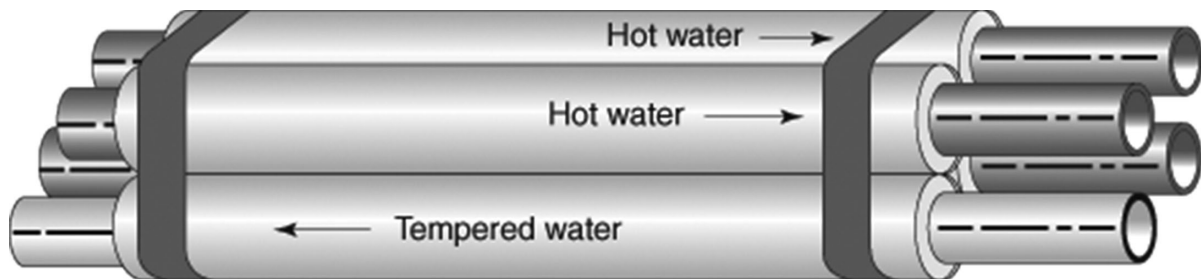

To prevent thermal transfer, the code requires each hot water pipe to be insulated when hot water piping is bundled with other piping. Bundles of PEX piping typically are held together loosely with plastic ties to allow for expansion and contraction of the individual pipes.

Code Text: *Gauges used for testing shall be as follows:*

- 1. Tests requiring a pressure of 69 kPa or less shall utilize a testing gauge having increments of 0.69 kPa or less.*
- 2. Tests requiring a pressure of greater than 69 kPa but less than or equal to 690 kPa shall utilize a testing gauge having increments of 6.9 kPa or less.*
- 3. Tests requiring a pressure of greater than 690 kPa shall utilize a testing gauge having increments of 14 kPa or less*

Discussion and Commentary: A test gauge must be chosen to accurately measure the air pressure and clearly indicate any drop in pressure so as to detect a leak in the piping system. For example, a test gauge with increments of 6.9 or 13.8 kPa will not provide the necessary accuracy when testing a piping system with only 34.5 kPa of air pressure. In such a case, a small drop in pressure would not be noticeable on the gauge.

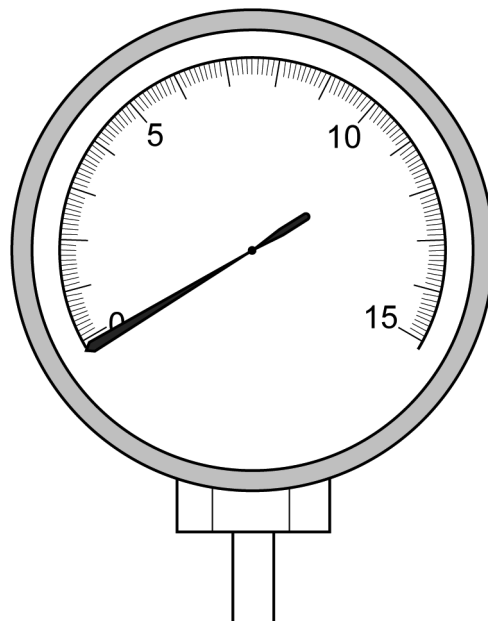

**PRESSURE GAUGE WITH
7 kPa INCREMENTS FOR
TESTING AT 70 kPa OR LESS**

The permit holder is responsible for performing the tests and giving reasonable advance notice to the code official that the system is ready for inspection and observation of the testing.