

Chapter 4: Wildland-Urban Interface Area Requirements

General Comments

This chapter provides the general requirements for the fire safety of a structure within the wildland-urban interface area. Many of the requirements in this chapter are also covered in the *International Fire Code*® (IFC®) if it is adopted. When two adopted codes address a specific item, such as water supply in Section 404, the project must comply with the most restrictive unless a specific ruling is made in the adopting ordinance.

Purpose

This chapter is intended to provide individual requirements for fire department access, water supply and site-specific fire protection plans within each wildland-urban interface area.

SECTION 401 GENERAL

401.1 Scope. *Wildland-urban interface areas* shall be provided with emergency vehicle access and water supply in accordance with this chapter.

❖ This section makes it clear that the requirements for vehicle access and fire-fighting water supplies in Chapter 4 apply to all areas within the wildland-urban interface area.

401.2 Objective. The objective of this chapter is to establish the minimum requirements for emergency vehicle access and water supply for buildings and structures located in the *wildland-urban interface areas*.

❖ This section makes it clear that these requirements are a minimum set of requirements. There may be other requirements in the jurisdiction that apply and are more restrictive. These other requirements could be minimum road design from the Road Department or Public Works Department that are more restrictive than the requirements herein. The requirements in Chapter 4 are minimum requirements, which means that new developments cannot provide something less than required here.

401.3 General safety precautions. General safety precautions shall be in accordance with this chapter. See also Appendix A.

❖ This section acknowledges that Appendix A, if adopted, may also apply. Chapter 4 has regulations applicable to building construction, access roads and water supply. Appendix A applies to the vegetation around the structure, along the roadways and adjacent to water sources.

SECTION 402 APPLICABILITY

402.1 Subdivisions. Subdivisions shall comply with Sections 402.1.1 and 402.1.2.

❖ See the commentary to Sections 402.1.1 and 402.1.2.

402.1.1 Access. New subdivisions, as determined by this jurisdiction, shall be provided with fire apparatus access roads in accordance with the *International Fire Code* and access requirements in accordance with Section 403.

❖ This section states that access requirements in the IFC, along with the requirements in this code, apply to new subdivisions. Section 503.2 of the IFC provides specific criteria for roadway, such as:

- Minimum roadway width of 20 feet
- Minimum roadway clear height of 13 feet 6 inches
- Roadway surfaces must be designed to support fire apparatus
- Inside turning radius must meet fire code official approval
- Turnarounds
- Construction of bridges
- Grade of the roadway
- Angle of approach and angle of departure

Sections 503.5 and 503.6 of the IFC deal with security barricades and gates across roadways. These requirements in the IFC must be complied with in addition to the requirements that follow in this chapter.

402.1.2 Water supply. New subdivisions as determined by this jurisdiction shall be provided with water supply in accordance with Section 404.

❖ New subdivisions are required to provide an adequate water supply for fire-fighting purposes. This requirement is intended to apply to new land splits creating a new subdivision, not an existing subdivision where a landowner decides to build on the existing lot. The term “new” should be construed to mean that the subdivision was created after the adoption of the code. These requirements would be applied at the time of land split, or subdivision review and approval.

WILDLAND-URBAN INTERFACE AREA REQUIREMENTS

402.2 Individual structures. Individual structures shall comply with Sections 402.2.1 and 402.2.2.

❖ The subsequent requirements for access and water supply apply to individual structures. These sections would apply to the existing lot where the landowner now decides to construct. In other words, the subdivision has already been created and these requirements would be applied at the time of building permit.

402.2.1 Access. Individual structures hereafter constructed or relocated into or within *wildland-urban interface areas* shall be provided with fire apparatus access in accordance with the *International Fire Code* and driveways in accordance with Section 403.2. Marking of fire protection equipment shall be provided in accordance with Section 403.5 and address markers shall be provided in accordance with Section 403.6.

❖ This section states that fire apparatus access roads shall be provided to new structures when either of the following situations occurs:

- A new structure is constructed on the property.
- A structure that was previously located on another property is relocated, or moved, to this new location. This structure could have previously been within the jurisdiction, or it could have been transported from outside the jurisdiction. The concept is that the structure was not on this specific piece of property before, and now it will be located on this piece of property.

Either of these two situations create a new structure on a piece of property located within the wildland-urban interface area. Therefore, the structure is new to this site and must comply with the access requirements applicable to new construction.

402.2.2 Water supply. Individual structures hereafter constructed or relocated into or within *wildland-urban interface areas* shall be provided with a conforming water supply in accordance with Section 404.

Exceptions:

1. Structures constructed to meet the requirements for the class of ignition-resistant construction specified in Table 503.1 for a nonconforming water supply.
 2. Buildings containing only private garages, carports, sheds and agricultural buildings with a floor area of not more than 600 square feet (56 m²).
- ❖ As with Section 402.2.1, the requirement for water supply is applicable to newly constructed structures and to structures moved to the site. While this section requires a conforming water supply, it also provides two exceptions.

Exception 1 addresses an option found in Chapter 5. Table 503.1 requires the structure to be more fire resistant if the water supply does not meet the code requirements. For example, in Commentary Figure 402.2.2, notice that when the water supply and the defensible space conform to the code requirements, Class 3 ignition-resistant construction is required. However, when the water supply is nonconforming,

Class 2 ignition-resistant construction is required. See the commentary to Section 503.1 for further information.

Exception 2 is designed to exempt small structures which do not exceed 600 square feet. These smaller buildings are not the primary structure and are considered to not present a great threat to the primary structure. Typically, buildings such as sheds and agricultural buildings do not present as great a loss.

**TABLE 503.1
IGNITION-RESISTANT CONSTRUCTION (PARTIAL)**

DEFENSIBLE SPACE ^c	FIRE HAZARD SEVERITY	
	Moderate Hazard	
	Water Supply ^b	
	Conforming ^d	Nonconforming ^e
Nonconforming	IR 2	IR 1
Conforming	IR 3	IR 2
1.5 × Conforming	Not Required	IR 3

**Commentary Figure 402.2.2
PORTION OF TABLE 503.1**

402.3 Existing conditions. Existing buildings shall be provided with address markers in accordance with Section 403.6. Existing roads and fire protection equipment shall be provided with markings in accordance with Sections 403.4 and 403.5, respectively.

❖ This section is intentionally focused on existing conditions. It states that if existing buildings do not have address markers, then they must be provided. This concept correlates with requirements in the *International Building Code*[®] (IBC[®]) and IFC. Section 505.1 of the IFC and Section 502.1 of the IBC both specify that address identification must be provided on new and existing buildings. Additionally, this section requires roads and fire protection equipment to be marked. Many existing roads in rural or undeveloped areas are not identified. This allows the ability to require road markers, which will aid in emergency response.

SECTION 403 ACCESS

403.1 Restricted access. Where emergency vehicle access is restricted because of secured access roads or driveways or where immediate access is necessary for life-saving or fire-fighting purposes, the code official is authorized to require a key box to be installed in an *approved* location. The key box shall be of a type *approved* by the code official and shall contain keys to gain necessary access as required by the code official.

❖ Fencing property and installing locked gates across driveways and roadways is not uncommon. This section allows the code official to require a key box to be installed. The fire department carries a key to unlock

the key box, which contains the key to unlock the gate or barrier. The fire department key to the key box is secured in the fire apparatus and is not a key that the public has access to. This provides a level of security for the property owner yet still allows the fire department to gain entrance through the locked gate. Many jurisdictions have a key that is shared by the fire department and the law enforcement agency. This allows access for both agencies through the locked gates.

403.2 Driveways. Driveways shall be provided where any portion of an exterior wall of the first story of a building is located more than 150 feet (45 720 mm) from a fire apparatus access road.

- ❖ The ability for the fire department to approach to within 150 feet of a structure allows the fire fighters to deploy preconnected hose lines, which are typically 150 feet in length. This rapid deployment of hose lines allows fire fighters to attack the fire quickly. See Commentary Figure 403.2.

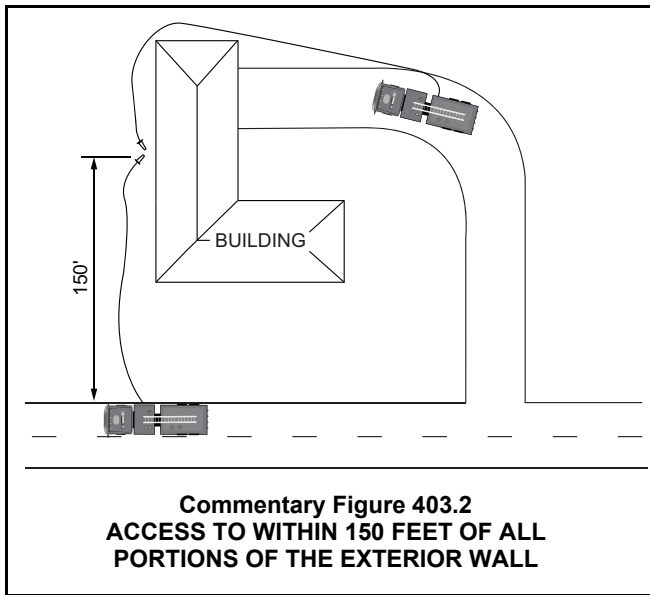

403.2.1 Dimensions. Driveways shall provide a minimum unobstructed width of 12 feet (3658 mm) and a minimum unobstructed height of 13 feet 6 inches (4115 mm).

- ❖ Where a driveway is required by Section 403.2, it must meet the minimum requirements in this section. The driveway must provide an unobstructed width of at least 12 feet, which is different from the road width of 20 feet required for fire apparatus access roads. This reduction in width is associated with the fact that the driveway is serving no more than five structures (Section 403.2.3) and single-vehicle travel is anticipated, whereas the fire apparatus access road is providing access into areas or subdivisions with vehicular traffic in both directions with the need to pass another vehicle freely. The minimum height of 13 feet 6 inches is the same as is required for fire apparatus access roads and is as needed to provide

clearance on both the driveway and the roadway for fire apparatus.

403.2.2 Length. Driveways in excess of 150 feet (45 720 mm) in length shall be provided with turnarounds. Driveways in excess of 200 feet (60 960 mm) in length and less than 20 feet (6096 mm) in width shall be provided with turnouts in addition to turnarounds.

- ❖ This section provides two criteria for design of driveways. First, where the length of the driveway exceeds 150 feet, an acceptable turnaround must be provided. The turnaround needs to be of such size that the fire apparatus can turn around. Without the ability to turn around, the fire apparatus would be forced to back out the driveway. The length of 150 feet is determined to be a reasonable distance to back up the fire vehicle, which is consistent with the requirement in the IFC. See Section 403.2.4 for additional provisions on turnarounds. See Commentary Figure 403.2.2.

Second, where the driveway is less than 20 feet in width and greater than 200 feet in length, turnouts are required. On these longer driveways, the possibility of needing to pass another vehicle or maneuver around an oncoming vehicle is greater. Turnouts provide the ability to complete these maneuvers. See Section 403.2.5 for additional provisions on turnouts.

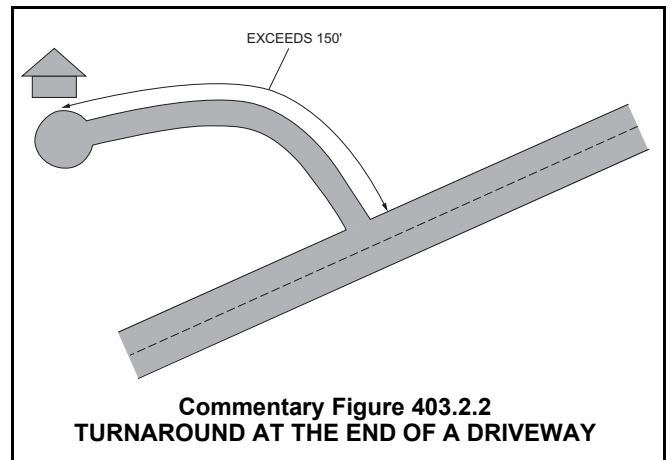

403.2.3 Service limitations. A driveway shall not serve in excess of five dwelling units.

Exception: Where such driveways meet the requirements for fire apparatus access road in accordance with Section 503 of the *International Fire Code*.

- ❖ According to Section 403.2.1, a driveway is only required to be 12 feet wide. If that is all the width provided by the driveway, it cannot serve more than five dwelling units. However, if the driveway is constructed as a fire apparatus access road and meets the criteria in the IFC, it is designed to a higher standard than that for a driveway and there is no limitation on the number of dwellings served. It would still need to provide a turnaround if it exceeds 150 feet in length, but the requirement for turnouts would not apply.

403.2.4 Turnarounds. Driveway turnarounds shall have inside turning radii of not less than 30 feet (9144 mm) and outside turning radii of not less than 45 feet (13 716 mm). Driveways that connect with a road or roads at more than one point shall be considered as having a turnaround if all changes of direction meet the radii requirements for driveway turnarounds.

❖ This section provides criteria for the design of turnarounds. The minimum inside turning radius of 30 feet is specified to allow larger fire apparatus to make the turns. This section also states that if the driveway connects to a road in more than one location, a turnaround is not needed. See Commentary Figures 403.2.4(1) and 403.2.4(2).

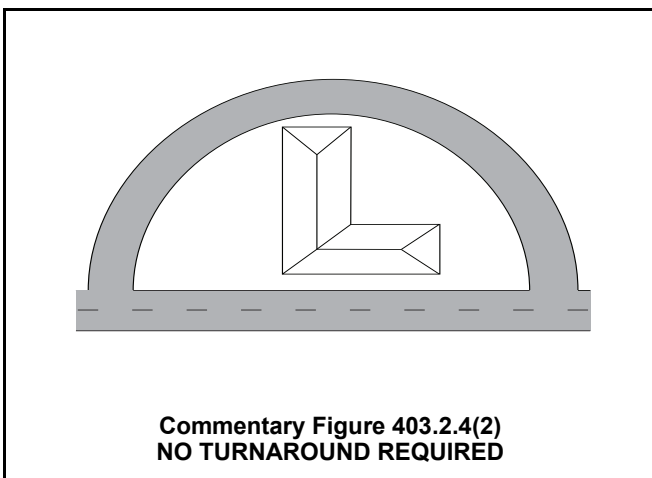
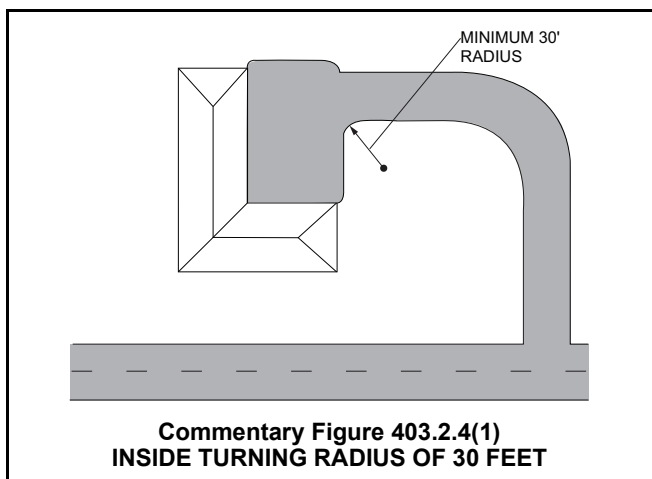

403.2.5 Turnouts. Driveway turnouts shall be an all-weather road surface not less than 10 feet (3048 mm) wide and 30 feet (9144 mm) long. Driveway turnouts shall be located as required by the code official.

❖ Turnouts in a driveway need to provide adequate space for two vehicles to pass one another. In accordance with Section 403.2.2, turnouts are required for driveways greater than 200 feet in length and less than 20 feet in width. A minimum size for turnouts is

specified as being at least 10 feet wide and 30 feet long. This size will allow a fire vehicle to pull into the turnout and allow another fire vehicle to pass. The code does not contain any criteria for distance between turnouts. This will be a decision made by the code official and should be based on the number of structures served by the driveway, the grade of the driveway, and the ability to construct turnouts based on the terrain. See Commentary Figure 403.2.5.

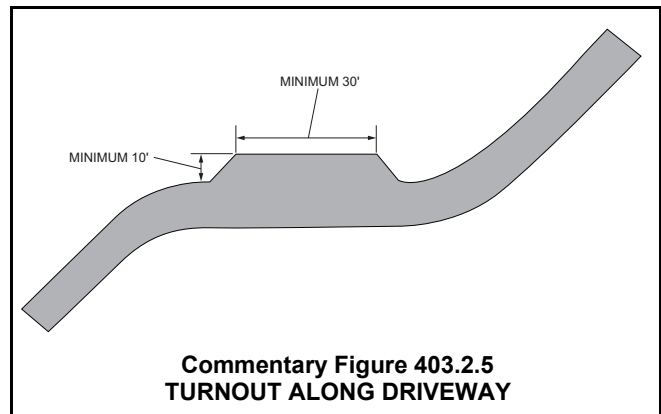

403.2.6 Bridges. Vehicle load limits shall be posted at both entrances to bridges on driveways and private roads. Design loads for bridges shall be established by the code official.

❖ The commentary to Section 402.1.1 stated that bridge design is specified in the IFC. Note that Section 402.1.1 applies to fire apparatus roads and Section 403.2.6 applies to driveways and private roads. As such, the bridge design standard in the IFC does not apply to a bridge constructed as part of a driveway. Therefore, this section states that the load limits must be identified at each end of a bridge. Fire apparatus can weigh upwards of 20 tons, which is far heavier than a typical vehicle. Therefore, when bridges are constructed as part of a driveway, their design load limit needs to be posted to warn firefighters that the bridge may not support the vehicle.

403.3 Fire apparatus access road. Where required, fire apparatus access roads shall be all-weather roads with a minimum width of 20 feet (6096 mm) and a clear height of 13 feet 6 inches (4115 mm); shall be designed to accommodate the loads and turning radii for fire apparatus; and shall have a gradient negotiable by the specific fire apparatus normally used at that location within the jurisdiction. Dead-end roads in excess of 150 feet (45 720 mm) in length shall be provided with turnarounds as *approved* by the code official. An all-weather road surface shall be any surface material acceptable to the code official that would normally allow the passage of emergency service vehicles typically used to respond to that location within the jurisdiction.

❖ This section specifies criteria for fire apparatus access roads. The section initially states that such roads must be all-weather roads; however, this is prefaced by the phrase "where required." This means that the code official may or may not require access

roads to meet these criteria. Typically, the requirements for roadways 20 feet wide with a clear height of 13 feet 6 inches and turnarounds for roads greater than 150 feet in length are in effect. There are times when the requirement for an all-weather surface is not required. Many rural areas have a roadway that is simply a graded road width. Often this decision is based upon what the jurisdiction is prepared to maintain because the access road is usually a public road, whereas the driveway is on private property and not the responsibility of the jurisdiction to maintain.

403.4 Marking of roads. *Approved* signs or other *approved* notices shall be provided and maintained for access roads and driveways to identify such roads and prohibit the obstruction thereof.

❖ Residents of the area may be completely familiar with the roads and where each one leads; however, responding firefighters are using maps to travel to a specific location. Without road names, response time is delayed. The section requires that signs are provided and maintained so they are not just installed at time of construction, but they must remain and be readable as long as the road exists.

403.4.1 Sign construction. Road identification signs and supports shall be of noncombustible materials. Signs shall have minimum 4-inch-high (102 mm) reflective letters with 1/2-inch (12.7 mm) stroke on a contrasting 6-inch-high (152 mm) sign. Road identification signage shall be mounted at a height of 7 feet (2134 mm) from the road surface to the bottom of the sign.

❖ This section specifies that road signs required in Section 403.4 must be of noncombustible materials with 4-inch-high lettering. Road signs are required to be noncombustible so that when fire sweeps through the area, the road signs have a chance of surviving. This requirement is similar to the requirements in Section 505.2 of the IFC for road signs.

403.5 Marking of fire protection equipment. Fire protection equipment and fire hydrants shall be clearly identified in a manner *approved* by the code official to prevent obstruction.

❖ Fire hydrants and fire protection equipment must be available and readily accessible when needed in an emergency. This section specifies that such equipment shall be identified in an approved manner. This potentially could be blue dots in the roadway if the road is asphalt or concrete, or it could be a flag attached to the top of the hydrant. Because most wildland fire areas experience snow in the wintertime, the flag is intended to be visible under several feet of snow so the fire fighters can locate the hydrant.

403.6 Address markers. Buildings shall have a permanently posted address, which shall be placed at each driveway entrance and be visible from both directions of travel along the road. In all cases, the address shall be posted at the begin-

ning of construction and shall be maintained thereafter, and the address shall be visible and legible from the road on which the address is located.

❖ All buildings shall have the address posted. This requirement is similar to the requirements in Section 505.1 of the IFC for posting building addresses on all buildings.

403.6.1 Signs along one-way roads. Address signs along one-way roads shall be visible from both the intended direction of travel and the opposite direction.

❖ This section requires that address signs be visible from both directions, even on a one-way road. Emergency situations may necessitate fire fighters to travel the opposite direction on a one-way road. In these situations, they need to be able to see the addresses before they pass the location.

403.6.2 Multiple addresses. Where multiple addresses are required at a single driveway, they shall be mounted on a single post, and additional signs shall be posted at locations where driveways divide.

❖ Section 403.2.3 states that a single driveway can serve up to five dwelling units. The exception to Section 403.2.3 allows an unlimited number of dwellings if the driveway meets the requirements of the IFC. In these cases, the address sign at the main road needs to list all of the addresses served by the driveway. If the driveway splits, additional address signs are required to provide direction to each specific address. See Commentary Figure 403.6.2.

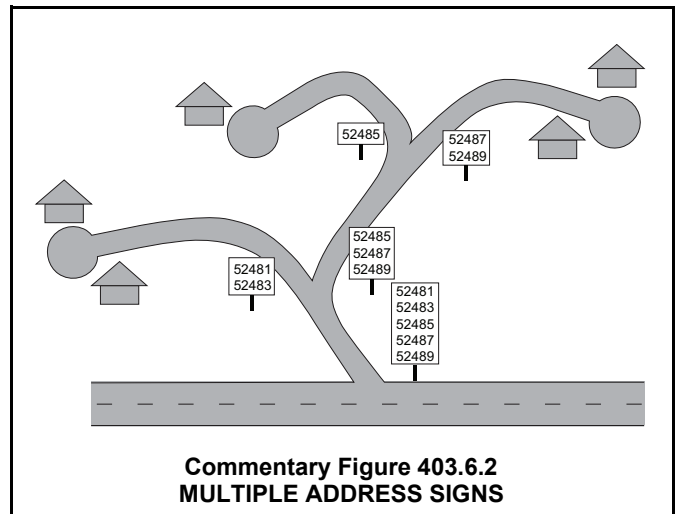

403.6.3 Single-business sites. Where a roadway provides access solely to a single commercial or industrial business, the address sign shall be placed at the nearest road intersection providing access to that site.

❖ While driveways often can serve multiple dwellings, typically business properties have their own individual

driveways or access roads. This section requires that the business address is identified at the roadway. Another reasonable option would be to provide the address on the building itself, provided the building is visible from the roadway. If the building is visible and the address is posted on the building, the address identification must be readable from the street. This is consistent with Section 505.1 in the IFC.

403.7 Grade. The gradient for fire apparatus access roads and driveways shall not exceed the maximum *approved* by the code official.

❖ The maximum grade of roads and driveways is limited to the maximum approved by the code official. As the grade of a road increases, the ability for fire apparatus to travel the road decreases and the response time increases. The weight of some fire engines can be up to 20 tons depending on the quantity of water and equipment carried. Even though NFPA 1906, *Standard for Wildland Fire Apparatus*, is not a referenced standard in the code, it is often used by fire departments when specifying new fire apparatus. According to NFPA 1906, the specifications for new fire apparatus must include the ability to travel at 20 mph up a grade of 6 percent. The annex to NFPA 1906 states that the fire department should specify additional grade criteria where operation on grades will be more frequent based on the terrain found within the jurisdiction. Note that since NFPA 1906 is not referenced in the code, it is not enforceable. The fire department will often have requirements specifying that the maximum grade is based on the road or driveway surface. For example, fire apparatus will have more difficulty traveling up a 12 percent grade if the road surface is compacted granite as opposed to asphalt or concrete.

This requirement is similar to the requirements in Section 503.2.7 of the IFC for maximum grade of fire apparatus roads.

**SECTION 404
WATER SUPPLY**

404.1 General. Where provided in order to qualify as a conforming water supply for the purpose of Table 503.1 or as required for new subdivisions in accordance with Section 402.1.2, an *approved* water source shall have an adequate water supply for the use of the fire protection service to protect buildings and structures from exterior fire sources or to suppress structure fires within the *wildland-urban interface area* of the jurisdiction in accordance with this section.

Exception: Buildings containing only private garages, carports, sheds and agricultural buildings with a floor area of not more than 600 square feet (56 m²).

❖ This section does not state that a water supply for fire fighting is required. Rather, it states that for the water supply to be considered a conforming water supply, it must meet certain criteria. This essentially means that even though there may be a water supply available at the site, it may not be a conforming water supply.

Therefore, the requirement for a water source for fire fighting does not originate in this code. Water supply for fire fighting is required in Section 507 of the IFC. Section 404 is used to determine the adequacy of the water supply to classify it as either conforming or nonconforming.

The intent of this section is to evaluate the water supply. This section is worded in this way to apply to existing buildings as well as new buildings, and to apply to a new building in an established subdivision. This code will classify the water supply and use that classification as part of the criteria in determining the required level of ignition-resistant construction.

To classify the water supply as conforming, the water supply must meet the requirements in Sections 404.2 through 404.10.3. Additionally, the exception states that the need for a conforming water supply does not apply to certain small buildings that are not normally occupied. These are the same buildings exempted in Section 402.2.2.

404.2 Water sources. The point at which a water source is available for use shall be located not more than 1,000 feet (305 m) from the building and be *approved* by the code official. The distance shall be measured along an unobstructed line of travel.

Water sources shall comply with the following:

1. Man-made water sources shall have a minimum usable water volume as determined by the adequate water supply needs in accordance with Section 404.5. This water source shall be equipped with an *approved* hydrant. The water level of the water source shall be maintained by rainfall, water pumped from a well, water hauled by a tanker or by seasonal high water of a stream or river. The design, construction, location, water level maintenance, access and access maintenance of man-made water sources shall be *approved* by the code official.
2. Natural water sources shall have a minimum annual water level or flow sufficient to meet the adequate water supply needs in accordance with Section 404.5. This water level or flow shall not be rendered unusable because of freezing. This water source shall have an *approved* draft site with an *approved* hydrant. Adequate water flow and rights for access to the water source shall be ensured in a form acceptable to the code official.

❖ One of the criteria for a conforming water supply is the location of the water supply with regard to its distance from the structure. The water supply must be within 1,000 feet of the structure. The distance of 1,000 feet originates from the Insurance Services Office (ISO) criteria for classification of properties for insurance purposes. The ISO requirement is that a fixed water supply must be within 1,000 feet of the structure to be considered usable at the site. If the water supply is further than 1,000 feet away, ISO considers that building as having no water supply.

The distance is measured along the path of travel that a fire apparatus would use in laying hose from the fire hydrant to the structure. The measured dis-